

Dal n° matricola **3950 +**

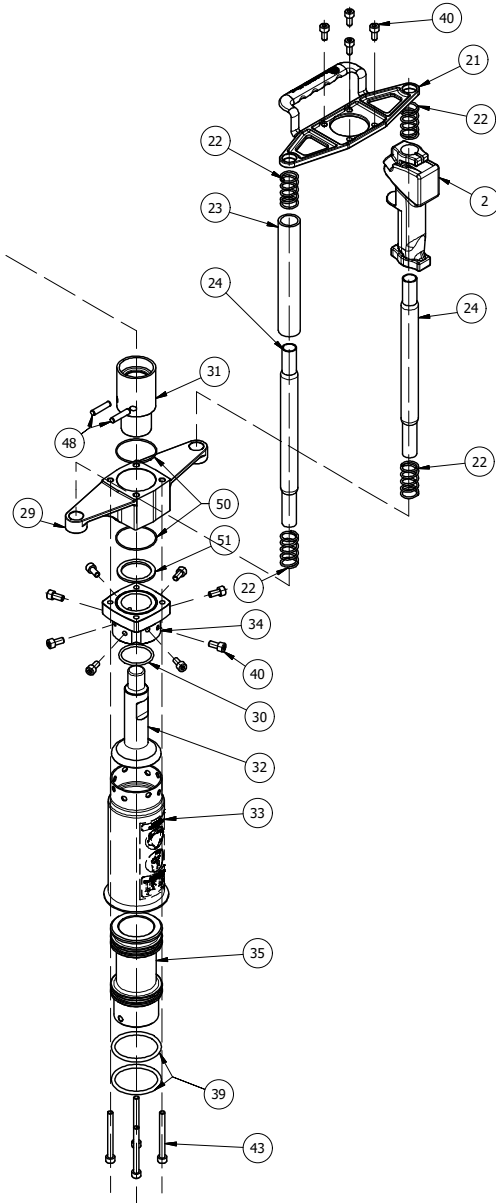

CHPD 78-1 PARTS LIST: SN 3950+

ITEM	QTY	PART NUMBER	DESCRIPTION
1	1	GX35	HONDA MOTOR
2	1	17850VL1741	THROTTLE LEVER ASSEMBLY
3	2	CEPD BS222	O RING
4	2	CEPD BS326	DAMPER O RING
5	1	CEPD 6000-2RS	DEEP GROOVE BALL BEARINGS
6	2	CEPD 6004-2RS	DEEP GROOVE BALL BEARINGS
7	1	CEPD 6201-2RS	DEEP GROOVE BALL BEARINGS
8	1	CEPD 20	HAMMER GUIDE
9	1	CEPD 22	DAMPER WASHER
10	1	CEPD 24-1	STEEL CYLINDER LINER
11	1	CEPD 27	TOP HAMMER
12	1	CEPD 30	PISTON
13	1	CEPD 31	CONNECTING ROD
14	1	CEPD 31-A	GUDGEON PIN 12 x 40
15	1	CEPD 37	COVER PLATE
16	1	CEPD 38	CRANK SHAFT
17	1	CEPD 38 PIN	CRANK PIN LH S1214
18	1	CEPD 54-58	S8T DRIVEN GEAR
19	1	CEPD 60-13	CLUTCH DRUM
20	1	CEPD 67-2	CAST CLUTCH HOUSING
21	1	CEPD 920	HANDLE MOUNT TOP BRACKET
22	4	CEPD 921-S	SPRING
23	1	CEPD 921-A	HANDLE RUBBER
24	2	CEPD 922	HANDLEBAR
25	1	CEPD 924	CRANK HOUSING
26	4	CEPD CC 20x1.20	EXTERNAL CIRCLIP
27	2	CEPD CC 42x1.75	INTERNAL CIRCLIP
28	1	CEPD A4x4x12	PARALLEL KEY
29	1	CEPD 925	CAST BOTTOM HOUSING
30	1	CEPD BS220	O RING
31	1	CEPD 936-1	HAMMER HOUSING (CEPD 78)
32	1	CEPD 937	3rd HAMMER (CEPD 78)
33	1	CEPD 934	BOTTOM GUIDE TUBE (CEPD 78)
34	1	CEPD 938-1	FLANGED ADAPTER (CEPD 78)
35	1	CEPD 930	REDUCER 78-54 mm
36	1	CEPD GUARD	CEPD GUARD
37	5	CEPD SPACER 8x5x10	SPACER 8x5x10
38	2	CEPD SPACER 8x5x14	SPACER 8x5x14
39	2	CEPD BS334	REDUCER O RING
40	12	CEPD M816 SHCS (M818)	M8 x 16 SHCS (M8x18)
41	4	CEPD M410 SHCS	M4 x 10 SHCS
42	11	CEPD M530 SHCS	M5 x 30 SHCS
43	4	CEPD M880 SHCS	M8 x 80 SHCS
44	2	CEPD M525 SHCS	M5 x 25 SHCS
45	2	CEPD M516 BHCS	M5 x 16 BHCS
46	2	CEPD M5 HEX NUT	M5 HEX NUT
47	3	CEPD M520 SHCS	M5 x 20 SHCS
48	2	CEPD PIN 8x36	PIN 8 x 36
49	1	CEPD BS040	O RING
50	2	CEPD BS035	O RING
51	1	CEPD DAMPER 3MM	PU FLAT WASHER
52	3	CEPD M5 WASHER	FLAT WASHER 10.9 x 5.7 x 1.3

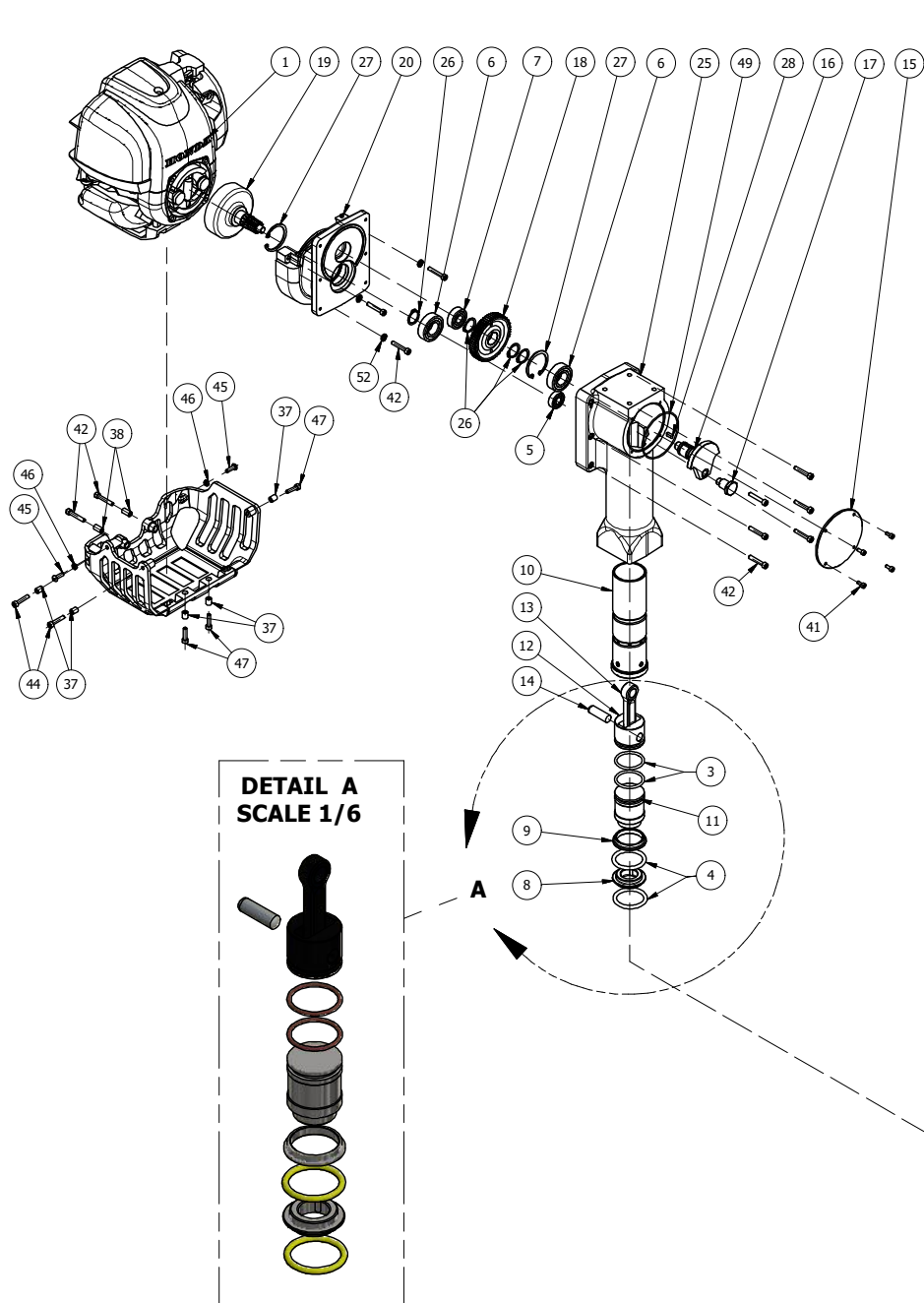